

REVISIONS				
REV	DESCRIPTION OF REVISION	ECN No.	DATE	APPROVED
A	INITIAL RELEASE	—	27/07/12	M. Dong

## TECHNICAL DATA

### Electrical

Impedance	50 Ω
Frequency range	0~50 GHz
VSWR	1.15:1
Contact resistance	
-centre contact	≤3mΩ
-outer contact	≤2mΩ
Insulation resistance	≥3000MΩ

### Mechanical & Environmental

Durability (matings)	>500
Temperature range	-55 °C ~ +165 °C
RoHS Compliant	Yes

### Material & Finish

Body	Stainless Steel (SU303), Passivated
Pin Contact	Beryllium Copper Alloy, Gold-plated
Insulator	PEI

### Interface Standards

2.4mm	IEEE STD 287-2007
-------	-------------------

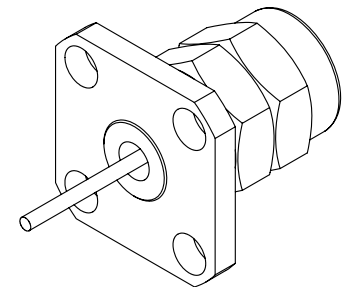
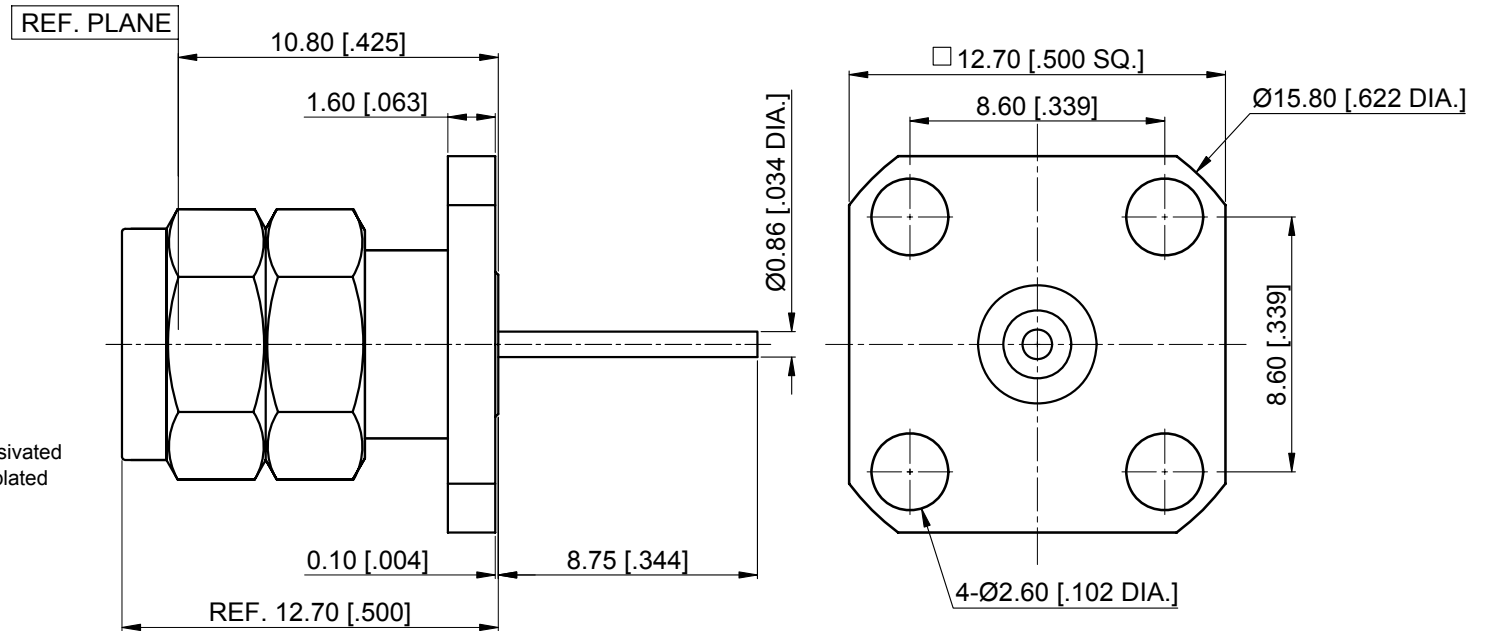

#### NOTES:

- ALL SPECIFICATIONS ARE SUBJECT TO CHANGE WITHOUT NOTICE AT ANY TIME
- UNLESS OTHERWISE SPECIFIED ALL DIMENSIONS ARE NOMINAL.

DRAWN:	W. Shen	27/07/12
CHECKED:	K. Liu	27/07/12
APPROVED:	M. Dong	27/07/12

UNLESS OTHERWISE SPECIFIED, DIMENSIONS ARE IN MILLIMETERS [INCHES].  
UNLESS OTHERWISE SPECIFIED DIMENSIONAL TOLERANCES ARE:

.XX	±0.13 [005"]
.X	±0.20 [008"]
X	±0.50 [019"]

ANGULAR TOLERANCES ARE: ALL=±1°

TITLE:

2.4mm Straight Male,  
Air Line Through the Wall,  
4 Hole Flange

**CONNOR**<sup>®</sup>

[www.connor.com](http://www.connor.com)

PART No.:

C11114028

DO NOT SCALE  
DRAWING

PROJECTION:

SIZE:  
A4

SCALE:  
4:1

SHEET:  
1/1

REV:  
A